



F'REAL B9 FOODSERVICE BLENDER

TURNKEY & HASSLE FREE

The f'real Blend n' Serve machine combines practicality and innovation to deliver an elevated experience whether you are using our 16oz customizable unbranded cups or our 12oz branded cups.



Features:

Efficient, High-Power Motor

- Stronger, more precise brushless motor for consistent product results
- Able to blend product in at an expanded temperature range, between +5°F and -5°F

Integrated Drip Tray

- Easy to wipe clean, never misplace

Wi-Fi or Cellular Connectivity

- Keeps software up to date and reduces service time
- Allows monitoring and diagnosing firmware/OS remotely

Vertical water reservoir

- Gravity based connection easily locks in place
- Thoughtfully designed tank allows it to be removed, filled, and replaced one-handed

Smart Blending Technology

- Digital screen with intuitive user menus.
- Custom blend thickness so operators can develop the perfect consistency for their beverages (adjustable water shot)
- Mix In Blend Profile - Staged blending to accommodate adding inclusions (syrups, purees, candy, cookies, etc.) and preserving piece identity (mouthfeel, texture, chunky pieces)

Warranty: 1 year warranty

ONE TOUCH CREATION OF:

- Shakes
- Smoothies
- Freakshakes
- Bowls
- Frappés
- Lemonades
- Cocktails

LET'S SHAKE THINGS UP.

1 Robert Rich Way, Buffalo NY 14213
 Call: (800) 483-3218
 Text: (816) 759-2249
 Email: support@freal.com
 www.richsusa.com/freal-foodservice/



B9 FOODSERVICE BLENDER

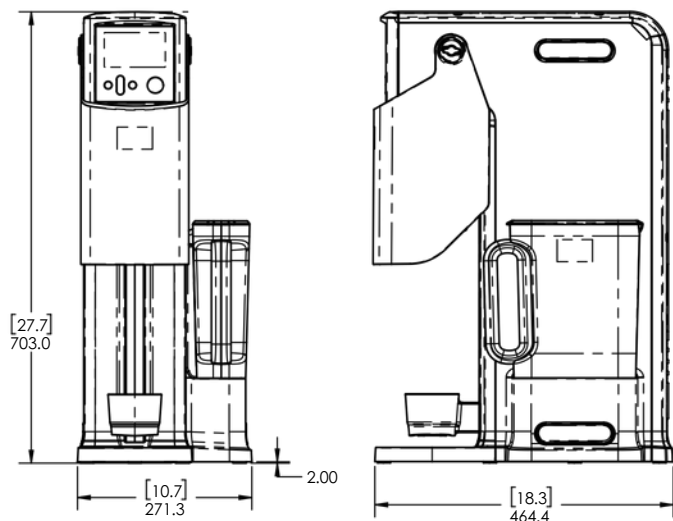

Model	frlb9
Power	120/60/1
Amps	15 AMP - dedicated circuit
Capacity	60 shakes per hour
Water Volume	2.74L (80 oz) Approx. 30 cups

Cord & Plug: Attached 9-foot flexible cord with molded plug fits into
Water: Use potable water. Filtered and/or low hardness levels are best.

Model	Dimensions	Net Weight	Shipping Dims	Shipping Weight
frlb9	11Wx28Hx18.3D	48.5 lbs	23Wx31.5Hx22.3D	55 lbs

CUPS AVAILABLE

PRODUCT CODE	PRODUCT DESCRIPTION	PACK/NON-BLENDED/BLENDED	SHELF LIFE FROZEN
80043	Made to Order Shake Base	12/9/16 fl. oz.	547 Days
80045	Made to Order Smoothie Base	12/8/16 fl. oz.	547 Days
80036	Blend & Serve Vanilla Shake	12/10/16 fl. oz.	547 Days
80050	Blend & Serve Chocolate Shake	12/10/16 fl. oz.	547 Days
80081	Blend & Serve Oreo Shake	12/10/16 fl. oz.	547 Days
80052	Blend & Serve Strawberry Shake	12/10/16 fl. oz.	547 Days
80053	Blend & Serve Strawberry/Banana Smoothie	12/10/16 fl. oz.	547 Days
80054	Blend & Serve Mango Smoothie	12/10/16 fl. oz.	547 Days
80055	Blend & Serve Coffee Frappe	12/9.5/16 fl. oz.	547 Days
02559	On Top® Original Whipped Topping	12/16 fl. oz.	540 Days

1 Robert Rich Way, Buffalo NY 14213
 Call: (800) 483-3218
 Text: (816) 759-2249
 Email: support@freal.com
www.richsusa.com/freal-foodservice/

